

## WIND-HYDRO POWER SYSTEM AS AN EXAMPLE OF DIVERSIFICATION OF DISTRIBUTED GENERATION

G. F. Kovalev, M. A. Rychkov

•  
(Institution of the Russian Academy of Sciences Melentiev  
Energy Systems Institute of the Siberian Branch of the RAS, Irkutsk, Russia)

e-mail: kovalev@isem.sei.irk.ru

### ABSTRACT

The paper considers using renewable wind energy for electricity generating. The system is characterized by high reliability and ecological purity. The authors briefly present the main methodological principles of choosing the parameters of the considered wind-hydro power system.

**Key words:** distribution generation, wind plant, reservoir, hydropower plant, electricity consumption, electricity supply, reliability, efficiency.

### Introduction

Nowadays renewable energy sources attract attention because the depletion of conventional nonrenewable energy (coal, gas, oil, etc.) is getting increasingly obvious. Wind energy is characterized by a considerable potential among the renewable resources.

Human civilizations have been using wind for a long time. In the Ancient times wind was used to propel boats. It is known that even 3000 years BC the citizens of Alexandria had used “wind wheels”. In the 16<sup>th</sup> century the Netherlands had more than ten thousand wind-driven plants that were used to dry lakes for cultivation area. In 1888 the USA constructed a large wind power plant for electricity production. The multi-blade wind motors invented by the engineer Davydov appeared at the Russian Exhibition in Nizhny Novgorod in 1896 [1]. Wind mills found wide application. In the USSR the first 100 kV wind power plant was built in the Crimea in 1931 and was in operation until World War II.

Currently wind energy is widely used in more than 60 countries of the world. Today 10 leading countries account for about 86% of all wind power capacities installed in the world, of which more than 38% are situated in China and the USA. In Europe wind energy is mostly used in Germany, Denmark, Spain, Portugal, and France. The total installed capacity in the world reached 194 GW [2] in 2011 and continues to soar.

When used as distributed generation, modern wind power plants along with advantages (free primary energy) have some drawbacks:

- lack of regularity and constancy in electricity generation due to variability of wind parameters;
- relatively high cost and low reliability;
- complexity of automated control of wind power plants both in case of their autonomous operation and in case of their operation within a grid;
- environmental problems (noise and allocation of large territories).

Elimination of these drawbacks is associated with additional costs of creating storage devices to replace generation capacities, sophisticated distributed automation of control system of parallel operation of a large number of wind generators “virtual power plant”; and removal of wind power plants from populated settlements to the uninhabited areas.

In this paper the authors take account of all the above circumstances and consider the advantages and disadvantages of a wind-hydro power complex (WHPC) that consists of wind - driven pumps, a storage capacity (water reservoir) and a hydropower plant.

An advantage of the system is its principal simplicity versus other designs of wind power plants and consists mainly in a simple scheme of converting power generated by the wind power plant.

The research aims to find out the conditions to make this system more efficient as compared to the other types of wind power plants. The authors suggest a technique for feasibility study on the efficiency of the wind hydropower system. Moreover, special attention is paid to reliability of power supply to consumers connected to such systems.

The main stages of the technique for calculation of parameters and estimation of the WHPC efficiency include:

1. Study on electricity consumption, load curves and requirements for electricity supply to the existing consumers.
2. Analysis of database on wind conditions (wind speeds and duration) in the studied area.
3. In the case of sufficient wind conditions – study and choice of water sources the most appropriate for the considered local conditions to be used to fill the hydropower plant reservoir with the aid of wind-driven pumps (available nearby water source: sea, lake, river, underground sources, etc.).
4. Determination of a required installed capacity of hydropower plant, characteristics of the main equipment and construction of the hydropower plant, taking account of electricity demand, load curves and reliability.
5. Collection of information on nomenclature and parameters of commercially manufactured hydropower units. Choice of an effective number of units and their rated capacity for concrete conditions.
6. Determination of a required capacity of reservoir and its main characteristics on the basis of local topographic and weather climatic conditions. The reservoir capacity can be increased depending on other economic needs of the region. Calculations of structures and hydro constructions of the reservoir.
7. Determination of the required installed capacity of wind-driven pumps and their characteristics, on the basis of requirements for reservoir filling within a calculation period determined by the wind speeds in this area and reliability requirements.
8. Acquisition of information about nomenclature and parameters of commercially manufactured wind-driven pumps. Choice of an effective number and delivery of the pumps to meet specific conditions, reliable and sufficient to fill the reservoir to the required level. A special order can be placed to manufacture exclusive pumps.
9. Preparation of technical and economic data for comparative estimation of the suggested and alternative variants, including the case of receiving electricity from power grid, and traditional wind power plants with capacities to backup them, etc.
10. Choice of the final variant of electricity supply in the region on the basis of feasibility study of the variants.
11. Solving the other problems related to the construction of WHPS. For example, consideration of possibility of WHPS operation using the reservoir in the low head of hydropower plant (HPP) to pump water from it to the upper reservoir with the aid of wind-driven pumps ( a closed cycle scheme), etc.

## Brief characteristic of the complex

The flowchart of the WHPC is presented in Figure 1. Its main modules are:

1. Reservoir filling module – wind-driven pumps.
2. Energy storage module – reservoir (water reservoir).
3. Generation module – HPP.

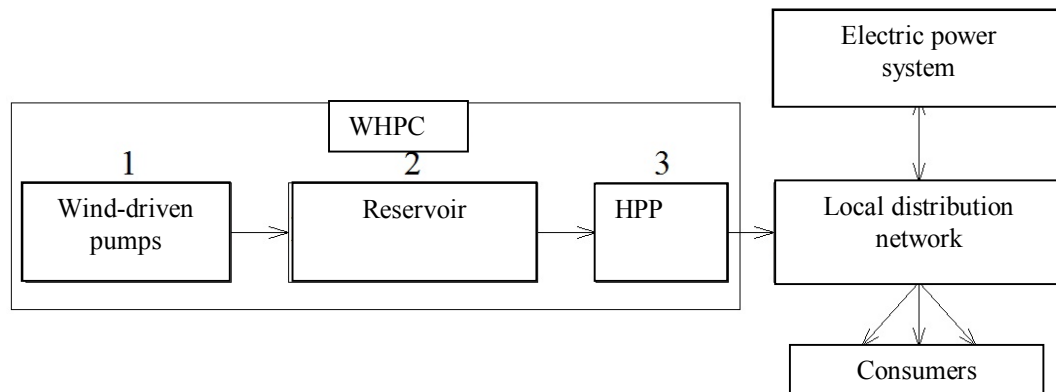

**Figure 1.** Flowchart of WHPC and its interfaces with the system of electricity supply to the area

As Figure 1 shows the idea of WHPC is not original. However, the reason why we address this issue is related to the circumstances that are growing urgent nowadays.

The essence of the suggested plant lies in the fact that wind being primary energy resource for WHPC operation is harnessed to fill reservoir which represents the energy storage stage in the cycle of electricity production. The major advantage of the WHPC is the combination of wind power plant advantages and the idea of pumped water storage. This excludes the main flaw of wind power generation, i.e. a mismatch between unpredictable variations in wind speed and electricity consumption schedule. This distinguishes WHPC from similar plants in which wind energy is used directly to generate electricity to meet the demand and to charge storage battery. When there is no wind and energy storage systems such plants are backed up by diesel power plants (DPP) or gas-turbine power plants (GTPP).

The wind-hydro power complex is in many parameters similar to the pumped storage power plants (PSPP) [3]. However, the main difference is the use of free wind power to fill the reservoir. The hydropower plant included in the system covers not only peak loads but the entire local load. Moreover, for WHPC the connection (at least a weak one) with power grid is desirable but not mandatory. With this connection WHPC can perform the functions imposed on distributed generation.

Compared to other wind power plants this system has the following advantages:

1. The WHPS designed according to such a flowchart makes it possible to separate and consider individually two random non-correlated processes:
  - the use of wind power for electricity supply under any wind conditions;
  - reliable (continuous) high quality electricity supply to consumers, irrespective of wind conditions at any time moment.
2. The possibility of applying relatively simple (and hence cheap and reliable wind-driven plants including wind-driven pumps with mechanical transmission of wind power to hydro pump (piston or centrifugal).

3. Application of reservoir as an energy storage which is environmentally friendlier and simpler than storage batteries of the same capacity, pressed air, hydrogen etc. as well as backup diesel units with diesel fuel stocks, or gas turbine plants.
4. Use of reservoir for the purposes other than storage, i.e. as a reservoir for tap water supply to the nearest populated settlements and productions, as a drinking place, for fish breeding, poultry farming, irrigation of agricultural lands, recreation needs, etc.

Application of such a system is efficient first of all for remote populated settlements because their full and reliable electricity supply from centralized power grid can be difficult or expensive. Although for the reasons of reliability and cost effectiveness WHPC can be constructed when consumers are supplied with electricity from grid. In this case the connection to the power grid can:

- increase the electricity supply reliability;
- decrease the reservoir capacity, particularly, if there are consumers of all categories. Then it is sufficient to use hydropower under emergency conditions to meet only the demand of consumers of the first category and partially of the second category;
- considerably improve power quality if transmission lines connected to the grid are very long and have a low rated voltage (110 kV and lower, down to 10-6 kV at lengths of 50-150 km and longer). Owing to HPP there will be local surplus active and reactive power for continuous electricity supply and voltage control;
- enable transmission of surplus power to the grid.

An additional advantage of the suggested system is the fact that to fill the reservoir it is not necessary to use high-speed wind machines, on the contrary it is more expedient to apply slow-speed wind-driven pumps. This increases the period of wind use and does not require such high aerodynamic characteristics as those necessary to use wind turbines to directly supply an electric load. The possibility of using natural relief of an area in order to construct a reservoir should also be considered as a benefit of the WHPS. The authors consider the possibility of applying such a system for electricity and water supply particularly in the arid regions.

However, along with the advantages the system has some flaws. First of all this is the impact of climatic conditions on water storage in the reservoir. With allocation of the plant in severe climatic conditions there appears a danger of reservoir and water supply system freezing and as a consequence the impossibility of their further use in the winter period. Elimination of this drawback requires additional investment. The relief of the territory may not always be suitable for the reservoir construction. Then it can be necessary to create an artificial water reservoir because of flat ground or insufficient ground strength which can lead to additional investment.

Taking into account the known electricity consumption variability over time electricity generation from WHPC should provide a reliable power supply to meet the demand.

Bearing in mind the advantages and disadvantages of the suggested system to clearly understand its efficiency as applied to specific conditions as well as to make a specific design it is necessary to develop an efficiency estimation technique as a calculation tool for solving the problem of electricity supply in specific conditions on the basis of renewable energy sources.

Thus, the technique for determining the WHPC parameters in general should include the following steps:

1. Calculation of HPP parameters on the basis of electricity consumption forecast and the need to provide reliable electricity supply to consumers;
2. Calculation of reservoir characteristics on the basis of calculated HPP parameters.
3. Determination of parameters for wind power plants on the basis of calculation results for p.2 and, bearing in mind wind characteristics of the area in which the plant is situated and reliability of wind-driven pumps.
4. Solving the other problems related to the construction of WHPC.

The HPP parameters, reservoir characteristics and parameters of wind power units are calculated using the known techniques but taking into account specific operating features of these facilities within the WHPC and estimation of the power supply reliability. Below the authors present the specific features of selecting the parameters and characteristics for the indicated components of WHPC.

### Determination of HPP parameters

Determination of HPP parameters in fact implies selection of a rated capacity and type of hydropower units with respect to selected head, and their number bearing in mind the required level of reliability of electricity supply.

The algorithm for calculation is as follows. After determining a regular annual load peak from the forecast of social and economic development of the region  $N_{reg.peak}^L$  for the respective time period we find an irregular annual peak  $N_{ir.peak}^L$  by the expression:

$$N_{ir.peak}^L = (1 + 3\sigma_L) N_{reg.peak}^L \quad (1)$$

In (1)  $\sigma_L$  is standard deviation of load from a regular value of capacity, per unit. It is known [4] that these deviations follow the normal distribution.

The optimal reliability of HPP is calculated according to the Bernoulli formula [5].

The method based on the Bernoulli formula makes it possible to estimate the required reserve and probability of shortage-free operation of the facilities consisting of  $n$  components according to their rated parameters. In order to assess reliability of HPP these parameters will be represented by rated capacity  $N_r$ , number of hydropower units  $n$  and probability of failure-free operation  $p$ . With the assumed  $N_r$  we determine the required number of units which will provide supply of the required load with a specified (rated) probability of shortage-free operation under the minimum capacity reserve.

The calculations are made according to the formula of binomial distribution

$$\begin{aligned} (p[N_r] + q[0])^n &= p^n [nN_r] + C_n^1 p^{n-1} q [(n-1)N_r] + C_n^2 p^{n-2} q^2 [(n-2)N_r] + \dots + \\ &+ C_n^i p^{n-i} q^i [(n-i)N_r] + \dots + q^n [0] = 1, \end{aligned} \quad (2)$$

where  $p$  – probability of operable state of hydropower unit (taken from the data of manufacturer or according to the emergency rate statistics for HPP equipment);  $q = 1 - p$  – probability of emergency downtime of the hydropower unit;  $n$  – the number of units to be installed at HPP;  $i = \overline{1, n}$  – the number of units that can be in an inoperable state;  $C_n^i$  – number of combinations from  $n$  units with respect to  $i$ ; expressions in square brackets characterize the values of the HPP available capacity in respective calculated states.

The presented binomial expansion is a full group of events with different possible states of the HPP components. In this case this is a combination of operable  $(n - i)$  and inoperable  $i$  components from their total number  $n$ .

From (2) we find the probability of shortage-free load supply:

$$P = \sum_{i=0}^l C_n^i p^{n-i} q^i [(n-i)N_r]$$

for all  $i$ , for which

$$(n - i)N_r \geq N_{ir,peak}^L \quad (3)$$

In this case we choose  $n$  for which

$$P \geq P_{std} \quad (4)$$

In (4)  $P_{std}$  is a standard value of probability of shortage-free electricity supply to consumers. In Russia  $P_{std}$  is assumed at the level of 0.996 [4], in Western Europe – 0.9996.

If (4) is not provided then  $N_r$  and/or  $n$ , at which (4) is met, varies.

Normally  $N_r$  is taken equal to the capacity given in the catalogues of plant manufacturers of hydropower equipment and the number of units  $n$  of the required rated capacity is specified.

Thus, from the above calculation we determine the main electric parameters of HPP: rated capacity of units  $N_r^0$ , number of units  $n^0$  and installed capacity of HPP

$$N_{HPP}^{inst} = n^0 N_r^0 \text{ kW.}$$

### Calculation of reservoir characteristics

At the second stage of calculation of the WHPC parameters we determine the required reservoir capacity.

Since wind conditions vary water supply to water reservoir varies too. The main objective here is to provide such volume and conditions for reservoir filling as to have sufficient water to meet the demand for electricity in a required amount and at a required time throughout the entire calculation period  $T$ , that depends on the wind conditions.

The wind conditions are estimated on the basis of data from climatologic reference books on wind for the area where the WHPS is going to be constructed. These data are used to determine the duration of periods with wind speed insufficient for operation of wind turbines and duration of energy inefficient wind speed. The two parameter Weibull distribution [1] is used in calculations to determine the repetition of wind speeds. The obtained information is then used to determine the duration of period with a wind speed that ensures useful work of wind-driven pumps.

In this case the calculation period  $T$  should be considered as

$$T = T_w + T_{i/w}, \quad (5)$$

where  $T_w$  – time of sufficient wind conditions, day;  $T_{i/w}$  – time of insufficient wind conditions, day.

Energy storage is used to solve the following problems:

- reciprocal matching of energy production and consumption schedules in order to provide uninterrupted electricity supply to consumers;
- increase in the efficiency of wind energy utilization through complete use of the total output of wind turbines.

When resolving the issues related to storage of energy produced by wind power plants we should take into account the following characteristics:

- relative sizes;
- duration of energy storage;
- admissible amount of energy to be stored;
- complexity of energy transformations (rectification, inversion, frequency transformation, etc.);
- simplicity and safety of maintenance, etc.



The main criterion for determining the reservoir capacity is the need to provide the required water flow rate  $Q$  by operating hydropower units. Flow rate decreases with an increase in the water head  $H$ . This condition is taken into account to design the reservoir in terms of the area relief.

The calculated water head is assumed according to the possibilities of reservoir construction in a specified area. With the assumed calculated head on the basis of manufacturer's data for the chosen type of hydropower unit we determine a specific water flow rate  $Q_0$  ( $\text{m}^3/\text{kWh}$ ). The required available reservoir capacity is determined by the formula

$$V_{avlb} = W_{req} \cdot Q_0 \text{ m}^3, \quad (6)$$

where  $W_{req}$  –required HPP output determined by the load curve for a respective calculation period  $T$ :

$$W_{req} = \int_0^T N(t) dt \text{ kWh},$$

where  $N(t)$  – required power of electricity consumption at hour  $t$  of the load curve.

Knowing the reservoir surface area  $F_s$  ( $\text{m}^2$ ), we estimate the depth of water layer of the available reservoir capacity:

$$\Delta H = V_{avlb} / F_s \text{ m.}$$

Based on the known  $H_{min}$  (from manufacturer's data) we determine the maximum head water level:

$$H_{max.} = H_{min} + \Delta H \text{ m.}$$

To estimate the reservoir surface area and depth of the available reservoir capacity we should seek to reduce the surface area (which decreases the alienation of land surface for reservoir, evaporation surface etc.), and the depth of periodic reservoir drawdown since large variations in the water level have a negative impact on the flora and fauna of the reservoir itself and its seashore. Generally, the reservoir surface area can be regulated by diking the reservoir of small sizes. The regulation of the reservoir surface area makes it possible to choose the depth of drawdown and vice versa, depending on the specific circumstances.

The selection of the hydropower units for WHPC implements the key principle of determining the reservoir capacity, i.e. makes it possible to provide the minimum possible flow rate  $Q$  in order to minimize the reservoir capacity and as a result decrease investment in its construction and operation.

Since an HPP supplies electricity to consumers, covering the whole of the load curve, the available reservoir capacity should satisfy the water flow rate by hydropower units for the assumed calculation period  $T$  of power supply. The calculation period can be taken equal to the time interval from a day (daily storage) to a year (yearly storage). The calculation period is chosen based on specific wind parameters – the more frequent is the wind, the shorter is the calculation period and hence, the smaller is the water reservoir and the lower is the investment in its construction.

In addition to the available reservoir capacity  $V_{avlb}$  to meet the water flow rate by hydropower units, account should be taken of losses caused by water evaporation  $V_{evap}$  from reservoir surface, by filtration  $V_f$  through ground and by ice formation  $V_i$  for the areas of cold climate [6, 7].

The methods for determination of water flow rate to compensate for these losses are empirical and applied depending on every specific case.

The total storage capacity will be

$$V_{total} = V_{avlb} + V_{evap} + V_f + V_i + V_{dead} = V_{av} + V_{loss} + V_{dead} \text{ m}^3,$$

where  $V_{loss} = V_{evap} + V_f + V_i$ ;  $V_{dead}$  – dead storage capacity.

Since construction of a purely man-made lake is an expensive measure, it is more expedient to arrange it on the basis of natural relief roughness with minimum involvement of materials and labor inputs in construction of a storage reservoir. The possibilities for provision of  $V_{total}$  at the site are evaluated by calculating the storage capacity of a prospective reservoir through the sequential summation of capacities  $\Delta V_i$  of individual layers between two adjacent contour lines on the topographic maps. This is done for determination of reservoir surface  $F_s$  by way of their planimetry based on the knowledge of topographic characteristics of the site.

In general the storage capacity  $V_{total}$  can be increased in case of the need to solve other economic problems in the area of WHPC construction that were mentioned above. This is, however, a separate problem.

The method of reservoir arrangement and its type by its design features are determined based on technical and economic indices of one or another variant for specific conditions. However, preference should be given to reservoir arrangement, taking advantage of natural relief as much as possible [6, 7].

At the initial stage of reservoir filling the wind-driven pumps will have to fill the total storage capacity  $V_{total}$ , which will require some time. Then after filling of the dead and available capacities, the wind-driven pumps will have to fill only the capacity  $V_{avlb} + V_{loss}$  to be emptied during the calculation period  $T$ . And the capacity filled in advance is emptied at the current period and simultaneously the new volume  $V_{avlb} + V_{loss}$  is stored for HPP operation at the next period.

Reservoir dislocation can be chosen based on a great number of variants: gorge, ravine, notch, depression on the upland. Apart from natural conditions, it is possible to consider creation of a man-made diked lake, a lake with consolidation of its bed with impermeable materials, etc.

### Calculation of wind-driven pump parameters

In operation of any plant using wind energy, including WHPC, the wind parameters are of prime importance as a source of energy production.

Wind depends on many complex geophysical and climatic factors. Its variability, therefore, can be predicted only with some probability that is determined as a result of statistical processing of the results of wind speed observations in the considered area for a long-term period.

Wind speed is the most important energy characteristic that estimates its kinetic energy. Under the impact of some meteorological factors (atmosphere perturbations, changes in solar activity and amount of heat energy arriving from the space to the Earth, etc.), and also the relief of the site, the wind speed changes in rate and direction. The powerful winds favorable for operation of wind power plants alternate thereby with calms.

The wind-driven pump capacity depends on the wind speed and the surface area swept by the wind wheel and is calculated by the formula:

$$N_w = \frac{v^3 D^2}{7000} \text{ kW}, \quad (7)$$

where  $v$  – wind speed, m/s;  $D$  – wind wheel diameter, m.

The wind-driven pump converts part of this capacity into effective capacity that is estimated by the wind energy utilization factor  $\zeta$ :



$$N_{w\ avlb} = \zeta \cdot N_w. \quad (8)$$

In general it is not expedient to use wind power plants for direct covering of electric loads without additional expensive smoothing and replacing facilities and also automatic controllers by virtue of essential distinctions between the consumer load curve and the curve of wind speed variation as random functions of time.

As was noted, the wind-driven pump (module for reservoir filling) capacity can be determined on the basis of the necessary storage capacity  $V_{avlb} + V_{loss}$  and the reservoir filling time  $T_r$  to be known, during the calculation period  $T$ . It is apparent that the dead storage capacity is filled once before the beginning of WHPS operation, and installation of additional wind-driven pumps for this purpose will be inexpedient.

The total pumping capacity of wind-driven pumps  $Q_{w\Sigma}$  is calculated by the formula:

$$Q_{w\Sigma} = \frac{V_{avlb} + V_{loss}}{T_w} \text{ m}^3/\text{s},$$

where  $T_w$  is in seconds.

The total delivery of wind-driven pumps is determined by the expression:

$$N_{w\Sigma} = \frac{9.81 Q_{w\Sigma} H}{\eta} \text{ kW}, \quad (9)$$

where  $\eta$  – pump efficiency;  $H$  – height of water, m.

The time of wind-driven pump operation  $T_w$  is determined from the formula in [1]:

$$T_w = \frac{f(v \geq v_0) \cdot T}{100}, \quad (10)$$

where  $f(v \geq v_0)$  – probability that the initial speed of the wind-driven pump will be exceeded, %;  $v_0$  – initial speed of the wind wheel, m/s. In calculations  $v_0$  is taken equal to 3 m/s. The multi-blade wind-driven pumps that are targeted for use in WHPS start to operate at this speed.

The values of  $f(v \geq v_0)$  as a function of the wind parameters  $v_0/\bar{v}$  and  $c_v$  are determined as tabular data in accordance with the Weibull distribution [1].

The down time of the wind-driven pumps  $T_{i/w}$  is determined as:

$$T_{i/w} = T - T_w \text{ h.} \quad (11)$$

The relation between  $T_w$  and  $T_{i/w}$  may be arbitrary, and the time of sufficient wind speed  $T_w$  may be both longer and shorter than  $T_{i/w}$ . The wind-driven pump capacity depends on the relation between  $T_w$  and  $T_{i/w}$ . The longer is  $T_w$ , the lower is the capacity  $N_{w\varepsilon}$ .

The rated capacity of the wind-driven pump  $N_{w\ rat}$  is chosen based on the machine industry capabilities. It is obvious that for these purposes the choice should be made of maximum possible capacity in terms of specific design conditions.

Then the minimum needed number of wind-driven pumps is calculated as

$$n_w = N_{w\varepsilon} / N_{w\ rat}. \quad (12)$$

The number of wind-driven pumps and their rated capacity considering reliability of wind-driven pumps can be evaluated more accurately on the basis of their emergency rate  $q_w$  to be determined and formula (2). The standard reliability of all the wind-driven pumps is taken as a

function of wind conditions in the considered region, however, not lower than the probability of shortage-free power supply (for RF – 0.996).

The described stages of WHPC calculation are basic for designing the considered plant. Technical and economic problems dealing with power supply from WHPC are solved at the next stage.

From the *technical* standpoint they include:

- generation of an electric circuit of hydropower plant, choice of voltages of generator, auxiliaries, master switchgear;
- generation of an electric circuit of local distribution network;
- assurance of reliability of power supply to consumers and required power quality in accordance with the standards of electric installation code, maintenance rules, and other documents;
- consideration of specific features of natural-climatic and geographical conditions for WHPS construction when being designed;
- implementation of capabilities for additional utilization of the man-made reservoir in socio-economic development of the region;
- assessment of WHPC security.

From the *economic* standpoint it is necessary to carry out a feasibility study on the effectiveness of the proposed system in comparison with other alternative options of power supply:

- 1) wind power plants in combination with replacing power sources (diesel power plants, geothermal power plants, etc.).
- 2) wind power plants in combination with storage facilities of other types (thermal, chemical, mechanical, etc.).

In addition one should bear in mind advantages of the suggested complex over the mentioned ones:

- simplicity of design;
- simplicity of meeting the main requirements to reliability and quality of power supply to consumers;
- wider range of economic usage (not only power generation).

Thus, the optimal decision for all these options can be chosen only based on the specific feasibility analysis that considers secondary advantages such as environmental.

### **Assessment of technical and economic effectiveness**

Technical and economic characteristics of the suggested WHPS should be determined to compare them with similar characteristics of other alternative power generation sources in the considered region and to estimate their dependence on local conditions.

The technical and economic characteristics of power supply options should be determined on the basis of their functional comparability: full satisfaction of demand, power supply reliability and power quality. Besides, one should bear in mind such advantages of WHPCs over other options as absence of fuel costs, simplicity, low cost and high reliability in comparison with wind power plants, substantially simplified control of WHPC, possibility for solving other (in addition to power supply) socio-economic problems in the considered region, higher environmental compatibility of WHPC, etc.

Effectiveness can be assessed based on the information about expenditures for both WHPS and alternative power supply options such as renewable and non-renewable energy sources, i.e. expenditures for construction of replacing diesel or gas-fired power plants, fuel cost, cost of diverse storage facilities and their practical limits on capacity.

For the most general case the expression for the simplified technical and economic evaluation of WHPS can be written in the following form:

$$aN_{WP} + bV_{total} + cN_{HPP} < dN_{WPP} + eN_{SF} + fN_{DPP} + gB_fW \frac{T_{i/w}}{T} n. \quad (13)$$

In this expression:

$a$  – unit cost of wind-driven pump (WP), RUR/kW;

$N_{WP}$  – installed capacity of WP, kW;

$b$  – unit cost of reservoir construction, RUR/m<sup>3</sup>;

$V_{total}$  – reservoir storage capacity, m<sup>3</sup>;

$c$  – unit cost of hydropower plant (HPP) construction (without reservoir cost), RUR/kW;

$N_{HPP}$  – installed capacity of HPP, kW;

$d$  – unit cost of wind power plant (WPP), RUR/kW;

$N_{WPU}$  – installed capacity of WPP, kW;

$e$  – unit cost of storage facility (SF), RUR/kW;

$N_{SU}$  – installed capacity of SF, kW;

$f$  – unit cost of additional power plant (DPP) construction, RUR/kW;

$N_{DPP}$  – installed capacity of DPP, kW;

$g$  – fuel cost for DPP, RUR/kg;

$B_f$  – specific fuel consumption by DPP, kg/kWh;

$W$  – required power generation for the calculation period  $T$ , kWh;

$T$  – calculation period corresponding to cyclic recurrence of wind activity at the considered site, hours;

$T_{i/w}$  – duration of calm period at the calculation period, hours;

$n$  – recurrence number of periods  $T$  during the WHPC service life.

Effectiveness is assessed on the basis of the following simplifications and assumptions.

The unit cost includes the cost of land allotted for facilities to be constructed.

Only the costs that differ in the options compared are calculated. Therefore, the proceeds from electricity trade that are assumed to be equal and the fixed costs for operation of compared power facilities are not taken into account.

Discounting costs during the service life of power facilities, which can hardly influence the basic compared option are not considered. Their service life is taken equal, i.e. 30 years.

If the cost of plants compared proves to be almost equal, preference should be given to WHPC owing to the indicated additional effects of its use.

The hydropower plant that is considered in this statement differs from the traditional run-of-river plant in the essential decrease of the probabilistic nature of water inflow to the reservoir. Here the necessary water volume is provided to a sufficiently high degree by installation of additional wind-driven pumps that deliver the needed volume of water at the periods of sufficient wind speed.

Expression (13) is of universal character to compare WHPC to any types of alternative options. Therefore, in the right-hand side there are zero values for the plants that are not used in the corresponding option.

The financial efficiency can be assessed by calculating the payback period:

$$T_{payback} = S/P = S/((C - Z)W_{year}),$$

where  $S$  – expenditures for the corresponding project (the right- or left-hand side of expression (13));

$P$  – annual profit from produced electricity sales;

$C$  – electricity price in the energy market;

$Z$  – electricity production cost;

$W_{year}$  – volume of annual electricity sales.

Preliminary analysis of the field of WHPC use has shown that these systems prove to be attractive in the range of power consumption from 30–50 kW to 10–15 MW. In this case at low

loads it is possible to have small ponds filled by two or three wind-driven pumps that deliver water at a height of 20-30 m rather than conventional reservoirs. WHPCs of higher capacity will require water heads of 100–150 m and higher (considering employment of diversion schemes). WHPCs of larger capacity become irrational because of vast areas required for allocation of wind-driven pumps and a reservoir.

An example of the comparative technical and economic evaluation of WHPC and an alternative power supply option (an additional diesel power plant as the cheapest alternative option) is presented below.

### Example of comparative assessment of technical and economic effectiveness of WHPC and an alternative option

The authors consider power supply to a coastal area of Lake Baikal [8, 9]. The annual regular maximum load is 650 kW. In accordance with (1) the irregular maximum load is taken equal to  $1.09 \cdot 650 = 710$  kW with  $\sigma_L = 0.03$ . The required power consumption for the calculation period  $T$  considering losses and auxiliary power supply will make up 1254144 kWh. The required HPP capacity considering uninterrupted power supply ( $P = 0.996$ ) will amount to 800 kW. Lake Baikal is the water source. The necessary reservoir capacity is  $0.00593 \text{ km}^3$ . Wind speed in the area allows the calculation period  $T$  to be taken equal to 3 months and the total time of energy-effective wind strength during the calculation period  $T_w$  to be taken equal to 1.6 months.

Two options are studied:

1. Wind hydropower system.
2. Wind power plant with an additional diesel power plant.

According to calculations in the first option the wind-driven pump **capacity** should be 2000 kW.

In the second option the wind power plant capacity equals 1100 kW, the diesel power plant capacity – 1100 kW (considering power supply reliability).

The technical and economic analysis was carried out based on the following averaged economic indices (see (13)):

$$a = 70000 \text{ RUR/kW};$$

$$b = 100 \text{ RUR/ m}^3;$$

$$c = 5000 \text{ RUR/ kW};$$

$$d = 51200 \text{ RUR/ kW};$$

$$f = 10000 \text{ RUR/ kW};$$

$$g = 30 \text{ RUR/ kg};$$

$$B_f = 0.4 \text{ kg / kWh};$$

$$n = 120 - \text{number of occurrences of periods } T \text{ during the power supply system life (30 years).}$$

The costs of construction and operation of the considered power supply options are calculated based on (13):

$$1. \quad aN_{WP} + bV_{total} + cN_{HPP} = 70000 \cdot 2000 + 100 \cdot 0.00593 \cdot 10^9 + 5000 \cdot 800 = 140000000 + 593000000 + 4000000 = 0.737 \text{ billion RUR.}$$

$$2. \quad dN_{WPP} + eN_{SF} + fN_{DPP} + gB_f W \frac{T_{calm}}{T} n = 51200 \cdot 1100 + 0 + 10000 \cdot 1100 + 30 \cdot 0.4 \cdot 1254144 \cdot \frac{31025}{2190} \cdot 120 = 56320000 + 0 + 11000000 + 845258680 = 0.913 \text{ billion RUR.}$$

The calculations show that the reservoir is the most expensive structure of WHPS (86.7 %). Hence, special attention should be paid to decrease of its construction costs. To make the

calculations more accurate it is necessary first of all to estimate the real value of  $b$  because of its impact on the cost of the first option. The WHPC competitiveness will increase with the fuel price rise (the costs of fuel delivery to remote areas are not taken into account and they are comparable to fuel cost and even exceed it).

The main conclusion from the indicated calculations is: effectiveness of the WHPC option depends on reservoir parameters. The smaller is the reservoir capacity, and correspondingly the unit costs, the more profitable will be the WHPC option. The indicated reservoir parameters can be decreased by increasing the head  $H$ , shortening the calculation period  $T$  and maximum possible utilization of natural relief elements for reservoir construction at the specific site.

## Conclusion

1. In the context of increasing shortage of fossil fuel resources and topicality of environmental problems the necessity of using renewable energy resources rises.
2. Investigations in the field of the most economical and technologically expedient renewable energy sources for specific areas result in designs of different systems, WHPC as an example.
3. The design works and commissioning of such a system can be realized on the basis of the technique for determination of its technical and economic effectiveness. The technique is to solve a great number of problems: from choice of the primary WHPC link – wind-driven pump to the final result – generation of power of the required quality for its reliable supply to consumers.
4. The technique should be applied as a tool for assessment of the efficiency of using the suggested system. All sorts of difficulties cannot be overcome successfully without flexible consideration of wind energy utilization forms.
5. Parameters of the required reservoir depend on the electric load, on the one hand, and the wind speed in the area of WHPC construction, on the other hand. The calculation period of reservoir drawdown is chosen based on the wind speed in the considered area. Therewith  $T_w$  is always shorter than  $T$ , and the shorter is  $T$  and the longer is  $T_w$ , the smaller will be the reservoir capacity and hence, the cheaper will be the WHPC construction.
6. The paper suggests a sequence of the WHPC calculation, choice of its basic parameters including power supply reliability and technical and economic effectiveness. The sequence of calculation is universal, i.e. it is applicable to any conditions of WHPC operation.
7. In general, WHPC plays a part of “distributed” generation that is defined as power generation at the point of its consumption. In this case the power losses and the costs of its transmission by regional power grids are excluded. Power supply reliability improves.
8. Availability of even a weak tie line with the power grid enhances flexibility, reliability and effectiveness of the local power supply system. Power quality in the considered area improves considerably. Besides, in this case excess power can be supplied to the common system network.
9. WHPC as distributed generation is of diversification character, allowing the variety of plants on renewable energy resources that utilize wind energy to be increased.

## References

1. Golitsyn M.V., Golitsyn A.M., Pronina N.V. Alternative energy carriers. – M.: Nauka, 2004. – 159 p. (in Russian).
2. Nikolaev V.G. Trend towards world wind energy development. // *Energiya: ekonomika, tekhnika, ekologiya*. 2011. P. 10–18 (in Russian).
3. Sinyugin V.Yu., Magruk V.I., Rodionov V.G. Pumped storage plants in the modern electric power industry. – M.: ENAS, 2008. – 358 p. (in Russian).

4. Power system design handbook./V.V. Ershevich, A.N. Zeiliger, G.A. Illarionov et al. Ed. by S.S. Rokotyan and I.M. Shapiro. 3d edition, revised and enlarged. – M.: Energoatomizdat, 1985. – 352 p. (in Russian).
5. Ventsel E.S. Probability theory. – M.: Vysshaya shkola, 2002. – 575 p. (in Russian)
6. Asarin A.E., Bestuzheva K.N. Hydraulic and energy calculations. – M.: Energoatomizdat, 1986. – 224 p. (in Russian).
7. Karol L.A. Hydraulic storage. – M.: Energiya, 1975. – 208 p. (in Russian).
8. Rychkov M.A. Choice of rated capacity and number of hydropower units at mini-HPP considering reliability. // System energy studies. Issue 40. – Irkutsk: ISEM SO RAN, 2010. P. 130–137 (in Russian).
9. Rychkov M.A. Determination of reservoir capacity for wind-hydro power complex. // System energy studies. Issue 41. – Irkutsk: ISEM SO RAN, 2011. P. 90–98 (in Russian).