

# LOW COST AUTOMATIC FIRE ALARM AND HAZARD LOCATION INTIMATING SYSTEM FOR INDUSTRIAL APPLICATION

B. H. Pithadiya<sup>1</sup>, H. N. Parikh<sup>2</sup>, H. N. Pandya<sup>3</sup>, H. N. Kapse<sup>4</sup>

<sup>1,2,3</sup> Department of Electronics, Saurashtra University  
Rajkot, Gujarat, India

<sup>4</sup>Department of Instrumentation & Control, Institute of Science &  
Technology for Advanced Studies & Research  
Vallabh Vidhyanagar, Gujarat, India  
pithadiyah2@gmail.com

## Abstract

*Burn tragedy is a significant hazard to human life and properties. Automatic fire alarm device allows for real-time tracking, monitoring and intimation. Once the fire happens, it gives early warning and helps to the fire loss. It is versatile security and alarm system which can be used by individuals, corporations or industrial establishments. The concept behind this project is to have a quick, easy, accurate and low-cost fire sensing and location-intimating device for users to get support in critical situations. The system can be positioned at any remote location that the consumer can quickly access with the aid of GSM technology. In this it is proposed that NodeMCU acquire signals from different sensors and control to manage communication with property owner. This is carried out by sending SMS immediately to owner in initial stage and to fire brigade in critical stage to resolve fire hazard. Different sensors incorporated within system are smoke, fire and flammable gas sensor. It helps to estimate specific threshold values in hazardous condition and alarms the buzzer accordingly. If in high emergency the system sends SMS consisting of the area and address location to the user / in charge person and fire brigade respectively.*

**Keywords:** Node-MCU (ESP8266), Smoke sensor, Flame sensor, Temperature and Humidity sensor, GSM

## I. Introduction

Wherever heat sources and flammable materials share a room, possibilities for fire occur. Many industrial sites contain highly hazardous content which can combust or burst into flames unless adequately handled and processed. An industrial fire is a form of industrial disaster which causes enormous damage to its sector. There are different ways in which this hazard is caused such as electrical fire, flammable liquids, compressed gases, hot work, housekeeping practices etc. The work environments in every industry pose unique fire hazard hence there lies some general issues culminating in a risk of fire or blast in industrial complexes or manufacturing facilities. Prevention ensures that a minor event or a small fire in a trash does not turn into a catastrophic event which can devastate a business or the lives of workers and a community.

Fire prevention is based on various hazard monitoring systems that include: Linear heat detection, Smoke Detection, CO and Combustible Gas detection, Emissions monitoring and many

others with technological developments, fire safety issues also have raised rapidly. Few researchers have tried to overcome this hazard monitoring in different ways viz. review of fire-detector types has been carried out by Omar Asif et.al. With development of microcontroller based automated fire alarm system for alerting fire incidents in household or industrial premises [1]. While Chen Thou et al. [2] worked on the early fire detection through image processing. The basic idea behind fire-detection was RGB (red, green, blue) model based chromatic and disorder measurement for extracting fire-pixels and smoke-pixels. Based on iterative checking on the growing ratio of flames, a fire-alarm was given when the alarm-raising condition is met. In other studies an emergency response system for fire hazards was designed with IoT standards for rescue operations for public safety by Ravi K. et.al.[3]. The system to improve home safety by getting immediate response about fire was implemented by Mahzan N. N. et.al.[4] while GSM based fire alarm system is suggested by Mao and Duan [5]. Lian used controller to get remote alarm for fire system [6]. This paper proposes framework of low cost multi sensor and alarm system with intimation of actual hazard location. To take precautionary measure and to avoid fire hazards or destruction especially in industrial setup this system has been developed. This works in two possible steps. First step is to inform the owner about the fire initiating signal so as to alert and to get in action whatsoever required. And the second step is to alert instantly to fire fighters also in case fire broke out exceeding threshold values.

## II. System components

### I. Node-MCU

Node-MCU is an open-source firmware and development kit that helps to build prototype. It includes firmware which runs on the ESP8266 Wi-Fi SoC from Espressif and hardware which is based on the ESP-12 module. It uses an on-module flash-based SPIFFS file of Systems. It is asynchronous and event-driven. Many functions, therefore, have parameters for callback functions.

The ESP8266 Node-MCU has total 17 GPIO pins broken out to the pin headers on both sides of the development board. These pins can be assigned to all sorts of peripheral duties, including: A 10-bit ADC channel, UART interface, PWM outputs, SPI, I2C & I2S interface, I2S interface etc.

The programmable ROM is programmed on-board via the USB, allowing the programming step to be easily integrated into the product manufacturing and testing process. Maintaining the Integrity of the Specifications

### II.SIM900A Modem (GSM)

SIM900A Modem is built with Dual Band GSM from SIMCOM. It works on frequencies 900 / 1800 MHz. The frequency bands can also be set by AT Commands. The baud rate is configurable from 1200-115200 through AT command. It is ultra compact and wireless module and allows connecting PC as well as microcontroller with RS232 Chip. It is suitable for SMS, Voice as well as DATA transfer application in M2M interface. It provides facility for audio calls and SMS attend the incoming calls through simple AT commands. This is a complete very powerful single-chip with serial and TTL outputs.

### III. Data Acquisition Sensors

There are four different components for acquiring data from the site.

#### A) Temperature & Humidity Sensor

Ambient temperature and humidity is measured using DHT11 air temperature humidity sensor. The DHT11 is a basic, ultra low-cost digital temperature and humidity sensor. It uses a capacitive

humidity sensor and a thermistor to measure the surrounding air, and spits out a digital signal on the data pin. Its fairly simple to use, but requires careful timing to grab data. And new data collected from it once every 2 seconds.

### B) Flame Sensor

Flame sensor is a device used to detect the presence of fire in its surrounding. For this system we have used **Infrared Flame Sensor** to detect the fire. It consists of a photodiode coated with black epoxy which makes it sensitive to the infrared radiations having wavelength between 700nm to 1mm and **can detect fire up to distance of 100cm within 60 degrees of angle of detection. Detection process is based on** the Infrared (IR) wavelength emitted by the flame.

### C) MQ2 Gas Sensor

It is metal oxide semiconductor sensor used for sensing the concentration of gases in the air. It comprises a sensing material whose resistance improves as it comes into contact with gas. This change in the value of resistance is used for the detection through voltage divider network. It can detect Propane, Hydrogen, Methane etc concentrations in the range of 200 ppm to 10000 ppm.

### D) MQ5 Gas Sensor

This sensor detects the presence of gas in an area. This module is useful for gas leakage detection of LPG, Natural gas, town gas and or smoke etc. Use the onboard potentiometer to adjust the sensitivity.

### E) Relay module

A relay switch is operated by an electromagnet which requires a small voltage for activation which is provided from the NodeMcu. When any one input from the sensor sense above threshold limit, relay switch activates bulb to switch ON. It helps to show emergency status of hazards area. Assembling all these components together makes a system, as shown in block diagram Figure 1

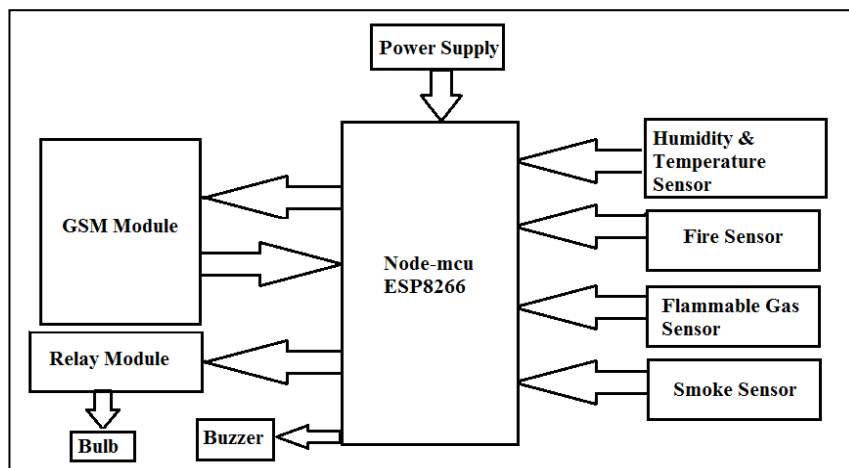

Figure 29 : System block diagram

## III. System operation

### I. Hardware

The actual circuit connection is shown in figure 2. In this circuit two main components are used. One is NodeMCU and other GSM module. Sensors are interfaced with NodeMCU as input devices while the GSM will execute process after getting signal from NodeMCU. The relay circuit will be activated

for alarming fire hazard to switch ON bulb and buzzer sounding. The circuit connection shows NodeMCU powered by Boost Buck module. Different sensors for detection are connected through this module for power requirements. The entire sensor devices are interfaced with NodeMCU as input devices. Flame sensor acts as electromagnetic radiation receiver. This sensor uses the infrared flame flash method, which allows the sensor to work through a coating of oil, dust, water vapor. While the smoke detection sensor MQ2 is used to detect the gases like methane, propane, concentrations if any present. This sensor includes a sensing part, primarily ceramic based on aluminum oxide, filled with Tin dioxide, embedded in a mesh of stainless steel. When immersed in air at high temperatures, oxygen is adsorbed on the surface of the sensing material. Instead donor electrons in tin oxide are drawn to this oxygen and hence the present flow is stopped. Such oxygen atoms interfere with the reduction of pollutants, thus reducing the surface density of the adsorbed oxygen when pollutants are present. Current will now pass via the sensor, producing analog voltage values. The quantities of these voltages are calculated to determine the gas concentration. Tension levels are higher when gas production is small. MQ5 is responsible for detecting smoke. The gas sensor module consists of an exoskeleton in steel that houses a sensing device beneath it. By connecting leads this sensing aspect is subject to current. If a gas interacts with this sensor, it is first ionized and then adsorbed by the sensing part. This changes the resistance of the sensing element which alters the value of the current going out of it. This adsorption creates a potential difference on the element which is conveyed to the NodeMCU unit through output pins in form of current. DHT11 sensor consists of a capacitive humidity sensing element and a thermistor for sensing temperature. The humidity sensing capacitor has two electrodes with a moisture holding substrate as a dielectric between them. Change in the capacitance value occurs with the change in humidity levels. This tests the modified principles of resistance and transforms them into digital shape. This sensor uses Negative Temperature coefficient of thermistor to measure the temperature, which causes its resistance value to decrease with increase in temperature. This sensor typically consists of semiconductor ceramics or polymers to achieve a greater resistance value except with the slightest temperature shift. The messaging GUI is designed for sending warning SMS. Sim900 interacts on UART platform with external device. The default Contact baud rate is 9600 bps. This requires setup and functional AT commands for it. NodeMCU Serial UART is used to interface the communication with sim900. Arduino IDE is used to compile and compose code. In the serial channel initialization feature is initialised. AT commands are sent to GSM in loop function. Note the cell number type to which the SMS must be submitted. The power is kept for ever at the end of the loop process while(1) process. If while (1) is not present, the loop feature runs continuously and SMS are continuously sent to the recipient.

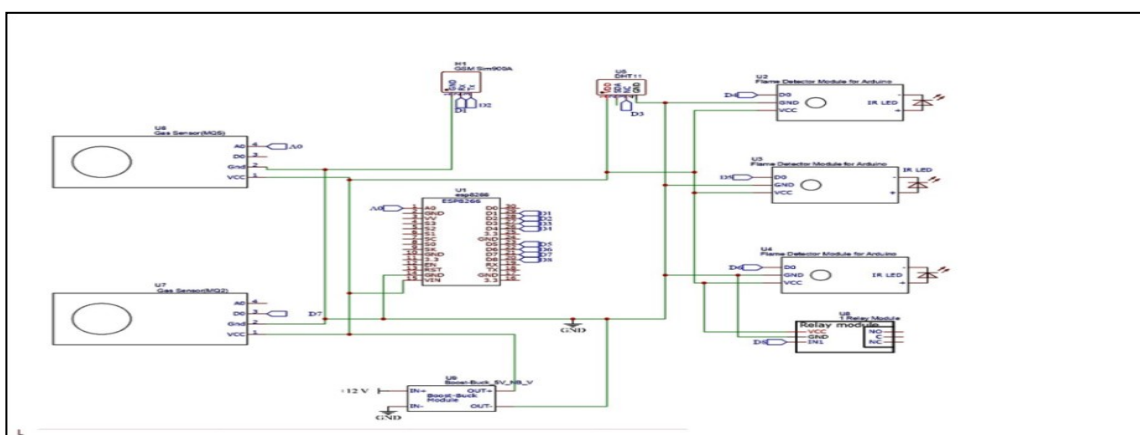

Figure 30: Circuit Connection diagram

## II. Software

This is preliminary step to begin with programming – need to initiate the system with following steps.

- Connect Node MCU to computer. Need a USB micro B cable to connect the board.
- Open Arduino IDE and Install ESP8266 board. Require at least Arduino IDE version 1.6.4 to proceed with this. Go to File > Preferences. In the "Additional Boards Manager URLs" field, type [http://arduino.esp8266.com/stable/package\\_esp8266com\\_index.json](http://arduino.esp8266.com/stable/package_esp8266com_index.json), and then click OK.

Then go to Tools > Board > Board Manager. Type "esp8266" in the search field

The entry "esp8266 by ESP8266 Community" should appear. Click install button.

- Select NodeMCU 1.0: Tools->Board dropdown Config the Board menu and choose the right Port for your device. CPU Frequency : 80MHz, Flash Size : 4M (3M SPIFFS), Upload Speed : 115200, Now the system is ready for coding.

### III. Experimental setup and Flow sequence

The figure 3 shows actual experimental set up for the low cost automatic fire alarm and hazard location intimating system for industrial application. The component working is explained in hardware section.

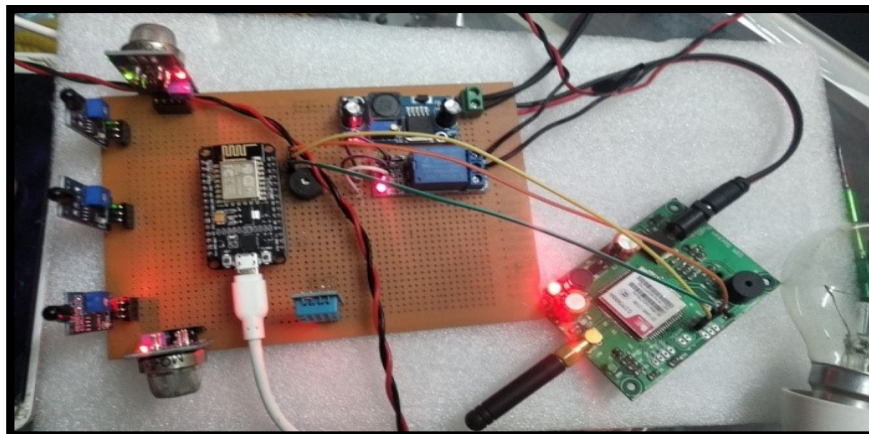

Figure 31: *Experimental setup of sensing system*

The flow sequence of detection and alerting system is shown in flow diagram figure 4.

### IV. Flow description

As shown in flow diagram (figure 4) at the initiation, controller checks for interface connectivity. If it finds ok, first SMS about activation is transferred through GSM module to owner's mobile. Each sensor is set to threshold limit. Controller checks the threshold value at preset time interval. Once initiation process is completed Sensor starts its function to detect. It gives logic 1 as output if any threshold limit is crossed otherwise its output remains in logic 0. NodeMCU continuously monitors these logical variations at output pin of sensor.

At any instance if the threshold value exceeds, sensor detects it and signals to NodeMCU. Message is sent to owner and warning indicators are activated, here buzzer and bulb. If more than one sensor exceeds threshold limits NodeMCU performs necessary actions to activate relays for the buzzer and bulb. At the same instant alert message is also sent to user and fire brigade about emergency.

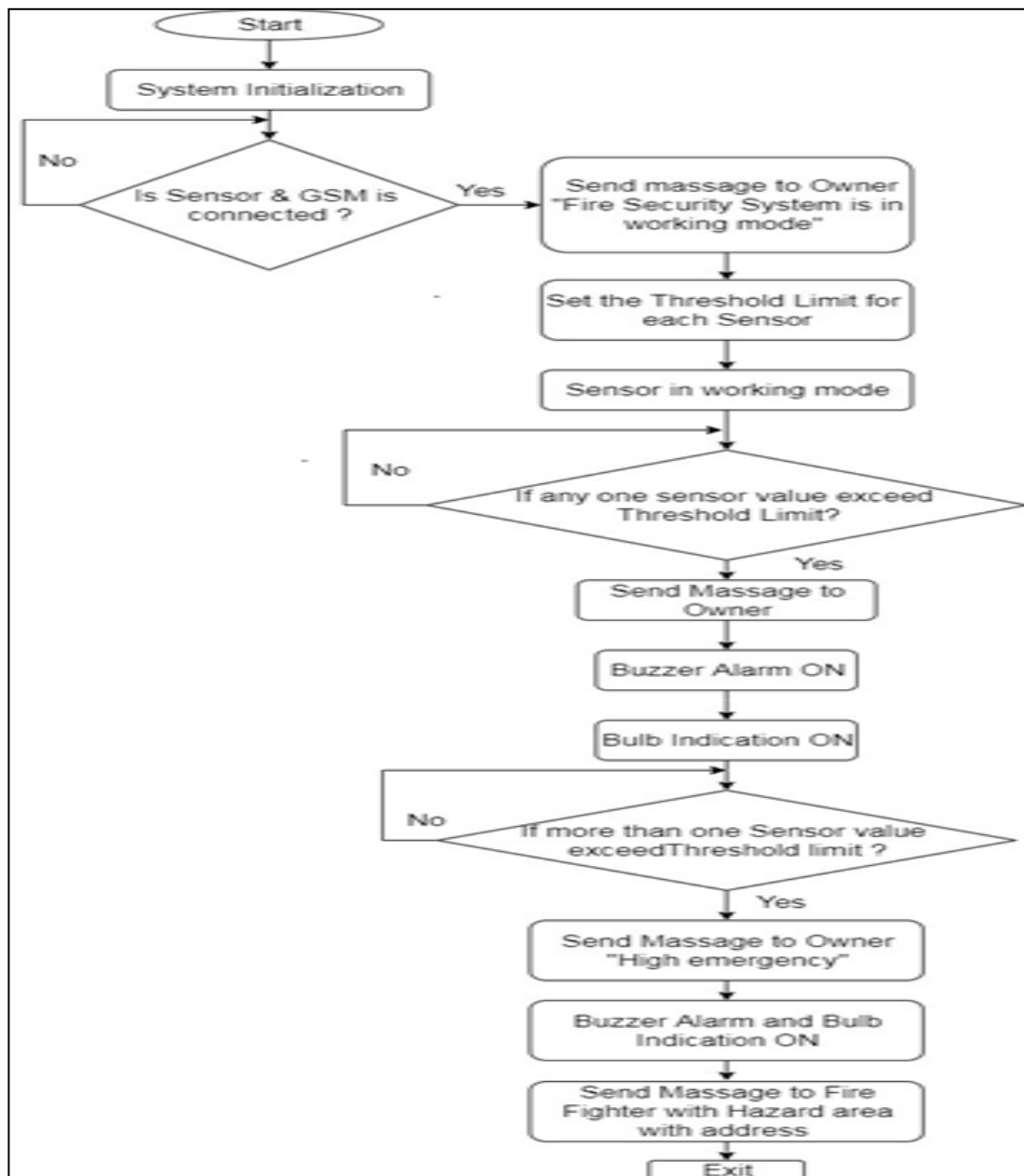

Figure 32 : Flow diagram

The beauty of this system is that fire fighter receive message with the address of hazardous area too. This enables them to directly track the spot for preventive actions.

The address is stored in memory of the installed device to avoid major losses in such hazardous conditions by instantly informing fire fighters team.

#### IV. Result

Tests were performed with differing conditions of smoke, air, and temperature to evaluate the system's efficiency and reaction to adverse fire circumstances. The results of the tests indicate that the program consistently provides appropriate warning responses under different test conditions. Figure 5 shows the experimental setup of the tests, where it indicates the condition of the bulb ON.

And the system responses in the form of SMS under different situations to the owner and fire fighter are shown in Figure 6a & 6b, respectively. Throughout the experiments, the system's transmission period from fire detection to warning message (SMS) via GSM network was on average 15 seconds for the owner as well as the fire fighter, which is fast enough to take the appropriate steps to stop the fire threat.

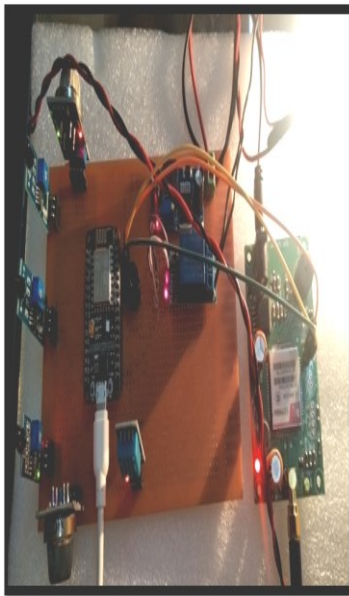

Figure 33: Indication Bulb ON detecting fire possibility

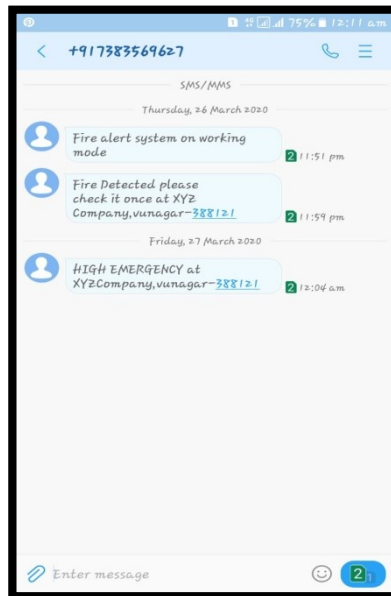

Figure 34a: Alerting SMS reached to owner

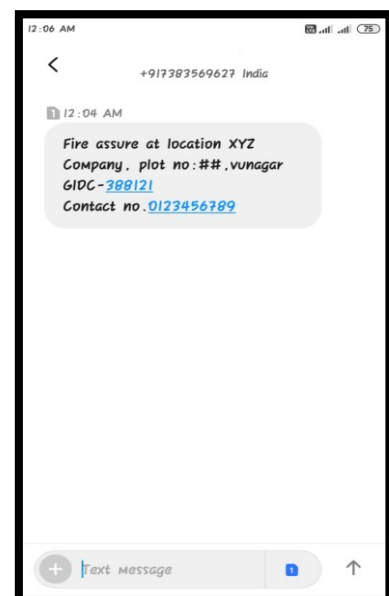

Figure 6b: Alerting SMS reached to Fire fighter with location intimation

## V.Conclusion

Fire tragedy presents a great threat to human life and property. In view of this a low cost automatic fire alarm and hazard location intimating system for industrial application is designed and implemented. NodeMCU being the significant controller comes in action whenever signals from sensors are received and act accordingly to communicate with GSM module to send SMS. Also it activates relay module to blow buzzer alarm at the local site area. This system provides an early fire warning which will help to prioritize the immediate rescue operations by owner and or fire fighters respectively so that damages will be reduced effectively.

## References

- [1] Omar A., Md. Belayat H., Mamun. H., Mir Toufikur R., and Muhammad E.H.C., "Fire-detectors review and design of an automated, quick responsive fire-alarm system based on SMS," Int. J. Communications, Network and System Science, 7 pp. 386-395, 2014
- [2] Thou-Ho C., Ping-Hsueh W., Yung-Chuen.C., "An early fire-detection method based on image processing" Conference Paper in Proceedings / ICIP International Conference on Image Processing 3: 1707 - 1710 Vol. 3, November 2004.

- [3] Ravi Kishor K. and Subbachary Y., "IoT based smart emergency response system for fire hazards" ,International Conference on Applied and Theoretical Computing and Communication Technology, 978-1-5386-1144-9@IEEE, 2017.
- [4] Najwa N. M., Nur I. M. , Nooradzianie M. Z. and Kyungjoo N., "Design of an Arduino-based home fire alarm system with GSM module", IOP Conf. Series: Journal of Physics:1019 (2018) 012079, doi :10.1088/1742-6596/1019/1/012079.
- [5] Mao L., Duan Q., "Research and design of GSM-based fire alarm system",The 11<sup>th</sup> Joint International Computer Conference (JICC2005).
- [6] Chun-Yuan L.,"Design of Intelligent fire alarm system based on GSM network", International Conference on Electronics and Optoelectronics, 978-1-61284-276-9/11@IEEE, 2011.